

# Chisholm 22

ADA-Compliant, Two-Room  
Vault Restroom Building

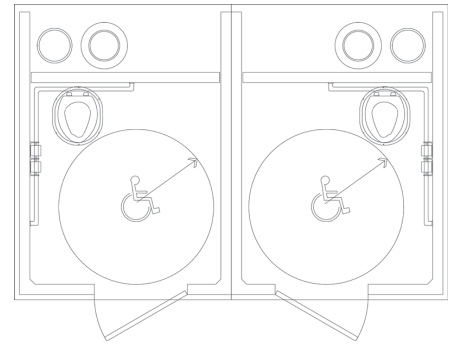
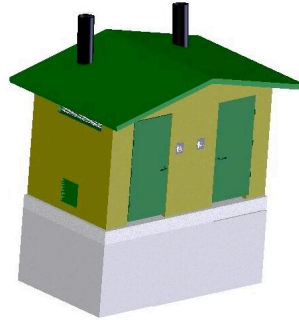

## DESCRIPTION

A superior, concrete, ADA-compliant, two-room vault restroom building, complete with floor, walls, gable roof, and two dry toilets. The **Chisholm 22** has a painted stucco exterior with a painted concrete roof. This model includes two ventilated holding vaults with service access and ships in four sections, two building and two vault sections.

## MATERIALS OF CONSTRUCTION

The **Chisholm 22** restroom facility is designed and manufactured to withstand average wind loads, snow loads and seismic activity for the specific geographic region in which it will be installed and in accordance with governing building codes and the stresses and shocks common to buildings.

**Building:** 5,000 psi concrete with steel reinforcement in the floor and walls tied together such that the floor is poured around the walls, thus providing superior strength and durability. Walls and roof are 4" thick; the floor is a minimum of 6" thick. All vertical building sections are joined with three welding surfaces, and the roof sections are welded to the walls. Doors and building vents are painted galvanized steel, with galvanized steel door frames attached in a manner that allows replacement, as necessary. Each **Chisholm 22** building section can be lifted as a single unit and positioned onto the pre-positioned vault sections.

**Vault:** 5,000 psi monolithic-pour, water-tight concrete with access port and vent incorporated into the floor of the restroom building. The interior wall surfaces are protected with a 30 mil, 2-part, moisture-cured, thermo-setting epoxy gel coat to provide a durable barrier between the corrosive quality of the human waste and the concrete walls of the tank.

## DIMENSIONS

Length: 14'0", Width: 9'8",  
Height: 9'6", Weight: 58,292 lbs.

## BUILDING FINISH

**Exterior walls and roof:** The exterior concrete walls of the building have a standard 5,000 psi stucco finish. Two coats of a modified latex exterior paint, as manufactured by Benjamin Moore, are applied at the factory. Colors for the exterior concrete walls and roof are selected by owner. The exterior roof has an application of a polyamide epoxy base coat followed by a 2-part aliphatic acrylic urethane coating, as manufactured by Benjamin Moore. Optional exterior surface reveals for the walls and roof are available.

**Exterior doors and frames:** These surfaces are primed, followed by 2 coats of urethane alkyd enamel. Color is selected by the owner.

## Interior Walls, Ceiling, and Floor:

The interior wall and ceiling surfaces of the building are steel troweled, followed by a 2-part polyamide epoxy coating, as manufactured by Benjamin Moore. The interior floor surface is steel troweled, followed with a broom finish. Because the floor is a high wear surface, a 2-part polyamide epoxy coating is available as an option. Colors for all interior surfaces are selected by the customer.

## APPLICABLE BUILDING CODES

- International Building Code
- International Plumbing Code
- International Mechanical Code
- International Energy Conservation Code
- US ADA National Accessibility Standards



All WalCon products are manufactured to the most rigorous design factors presented in the International Building Code for all geographical areas within the continental United States, with the exclusion of barrier islands.



Since 1980.

WALCON. A DIVISION OF WALLIS CONCRETE, LLC.

[www.walcon.com](http://www.walcon.com)

P.O. Box 1135, Wallis, Texas 77485 1-800-852-7880 | 979-478-7314 | Fax: 979-478-6753

\*WalCon is a registered trademark of Wallis Concrete, LLC. ©2010, Wallis Concrete, LLC.

012110